

FRONT VIEW

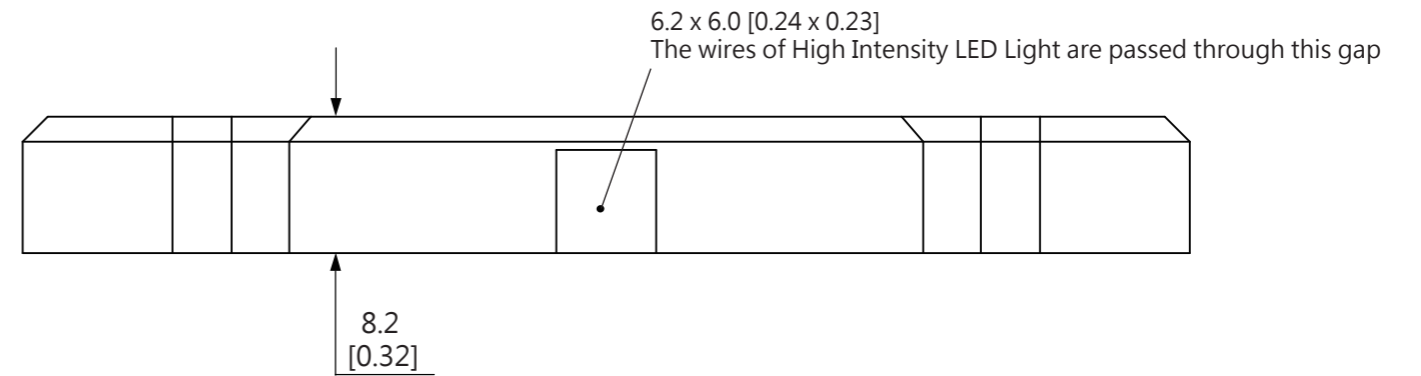

BOTTOM VIEW

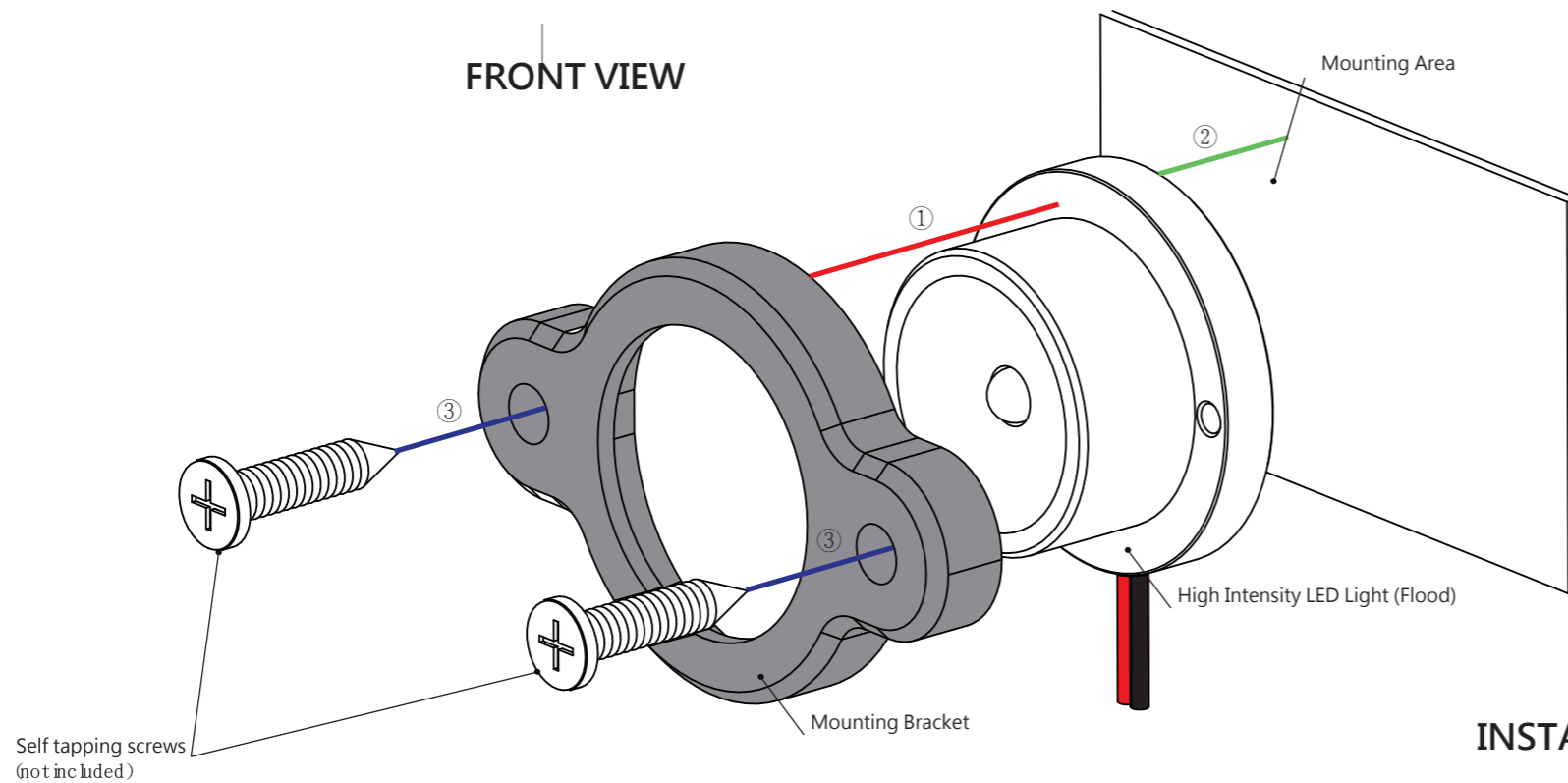

INSTALLATION DIAGRAM

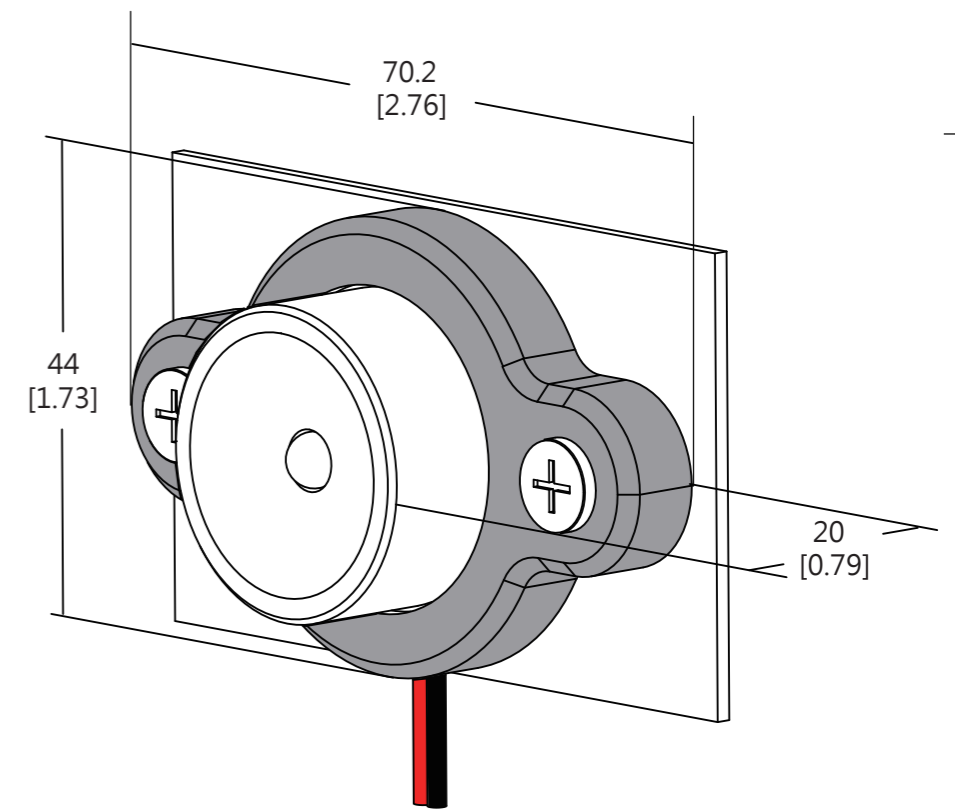

Technical Information (Per module):		
Net Weight: 15.5g		



PRODUCT NAME: Mounting Bracket for High Intensity LED Light		
VERSION: High Intensity Flood Light Installation		
PRODUCT NUMBER:	REVISION: B	PAGE: 1 of 2

All dimensions in millimeters [Inches]

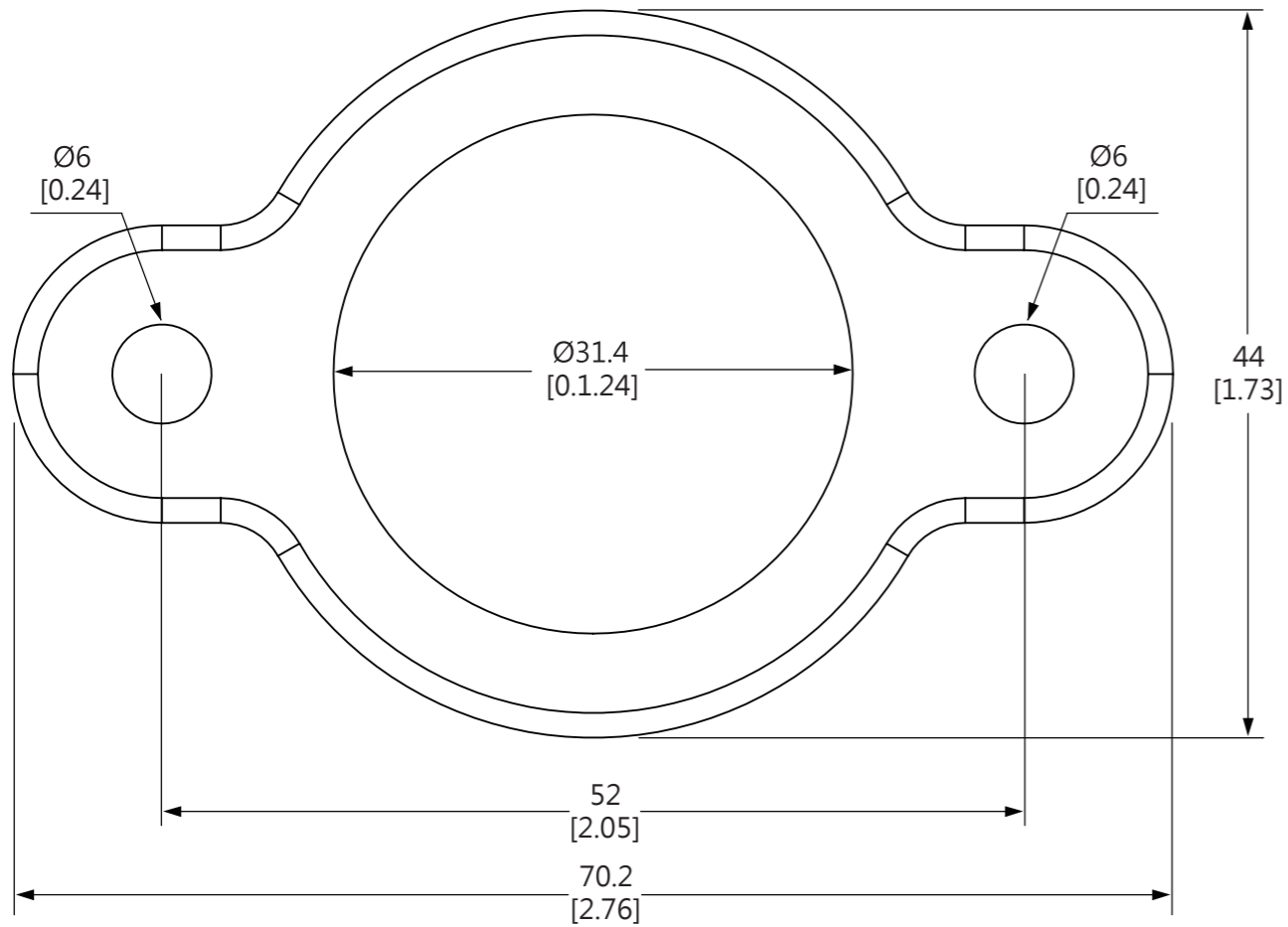

FRONT VIEW

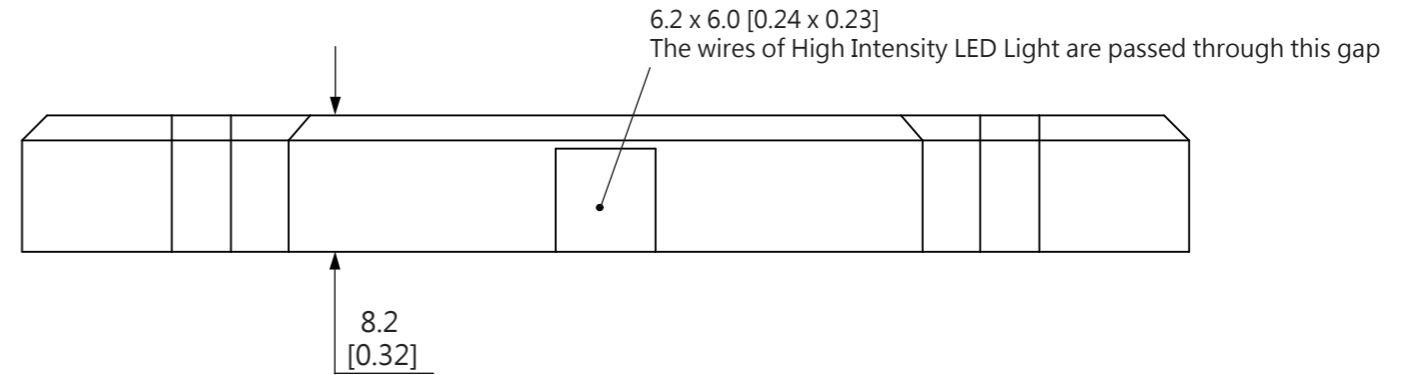

BOTTOM VIEW

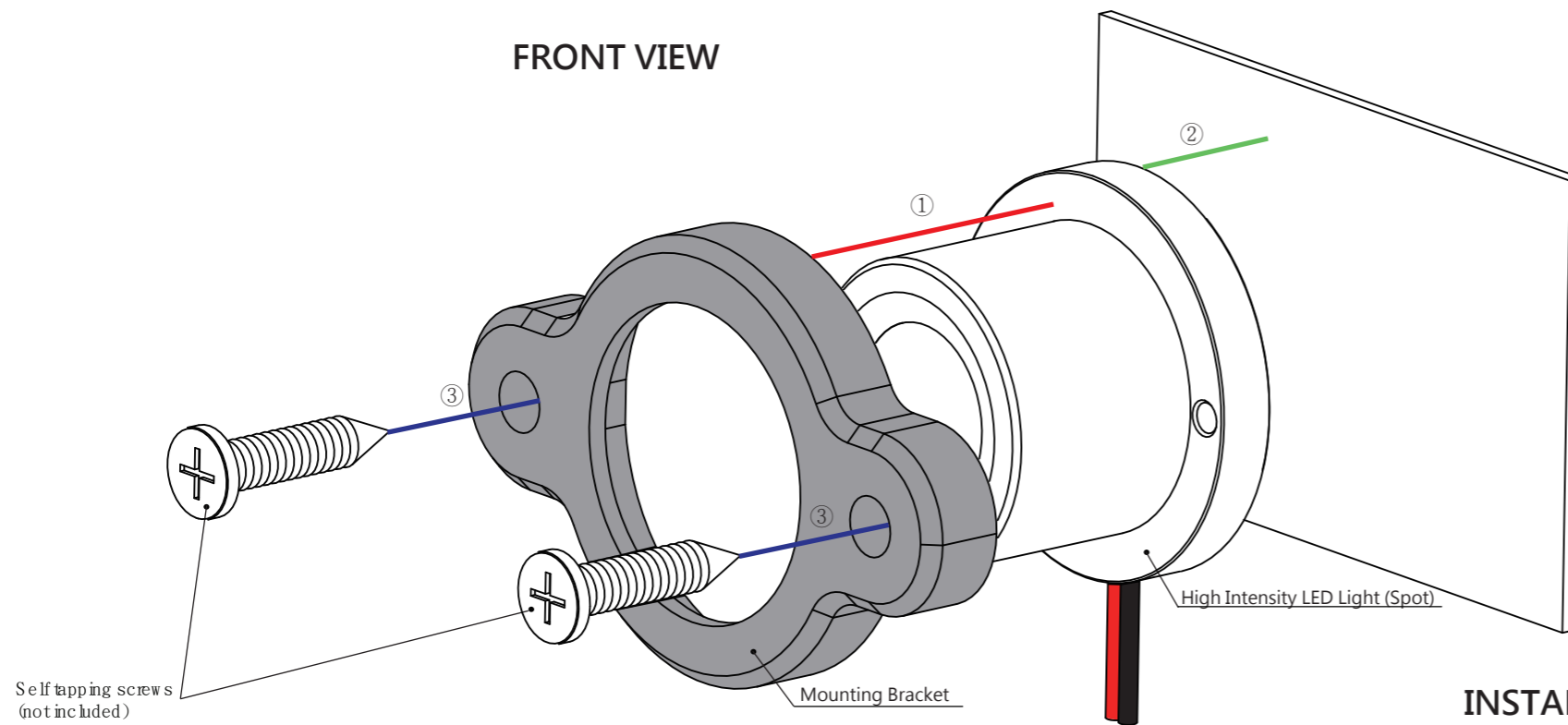

INSTALLATION DIAGRAM

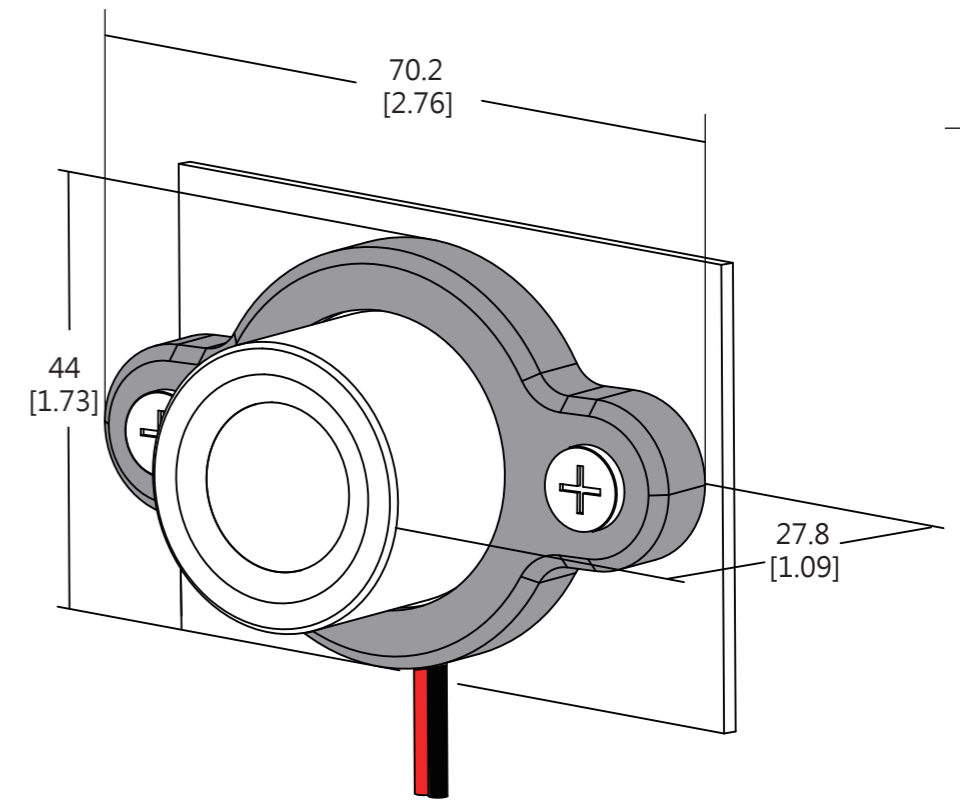

Self tapping screws
(not included)

Mounting Bracket

High Intensity LED Light (Spot)

Technical Information (Per module):

Net Weight: 15.5g



PRODUCT NAME:
Mounting Bracket for High Intensity LED Light

VERSION:
High Intensity Spot Light Installation

PRODUCT NUMBER: REVISION: PAGE:
B 2 of 2

All dimensions in millimeters [Inches]